

**WARNING:** Bikes or rack falling in road can cause serious accidents resulting in bodily injury—do not use rack on any vehicle on which it can not be properly mounted as described in this instruction sheet.

- Rack must be completely set up to safely transport bicycles.
- Top hooks must be completely hooked over solid metal edges at top/ front of trunk lid or rear door—never hook to rain gutters, roof racks, vertical glass, rubber or plastic moldings.
- Never use on front of vehicle. Mount rack only with bottom foot on a rigid surface of car (never on glass), and with bottom foot fully extended.
- Max capacity of rack is 2 Bicycles (**MAX CAPACITY: 70 LB**) - no tandems, electric bikes, mopeds, or recumbents.
- Bike must be securely tied to rack. Use attached tie-down cradles, or additional straps if necessary.
- Car tail lights must remain visible. Drive conservatively, especially over bumps. Never use off-road. Remove rack from vehicle when not in use.
- Do not use if any part of the rack is damaged, worn, or missing. Visit [www.allenracks.com](http://www.allenracks.com) for replacement parts.

**CAUTION:** Use Allen MT-2 only in accordance with local motor vehicle and traffic regulations.

- To avoid damage to rear door or trunk, do not open trunk or rear door when hooks or rack are in place.
- Install rack and load bicycles only at a safe distance from moving traffic.
- Only rubber pads and rack should come into contact with car.
- Make sure that all of rack and bicycles are kept at a safe distance from road and hot exhaust.
- Remove rack from car when not in use

## A. SETTING UP RACK:

**NOTE:** TO RETURN RACK TO FOLDED POSITION, REVERSE STEPS BELOW.

1. START WITH RACK IN A FOLDED POSITION

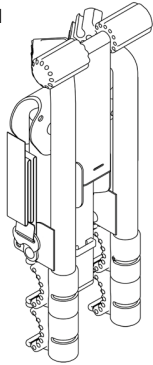

2. ROTATE TIE-DOWNS, AND
3. FULLY EXTEND BOTTOM FOOT

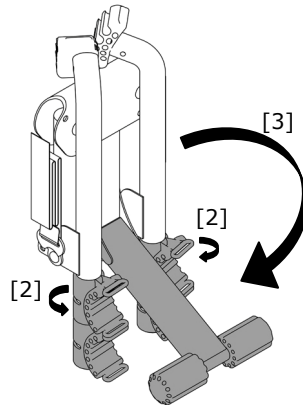

4. ROTATE BOTH TOP FEET DOWN BY 90 DEGREES TO OPEN, FULLY ENGAGING PINS

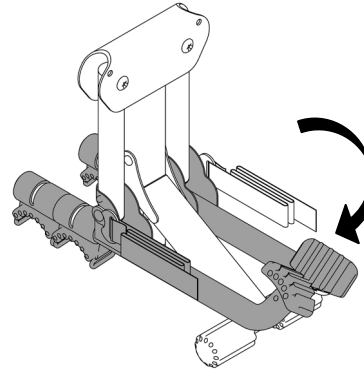

5. ROTATE CARRY ARMS INTO AN UPRIGHT POSITION, FULLY ENGAGING POP-UP PINS

6. RELEASE POP-UP PINS ON FRONT FEET AND EXTEND CARRY ARMS, MAKING CERTAIN THAT POP-UP PINS FULLY ENGAGE WHEN ARMS ARE IN EXTENDED POSITION.

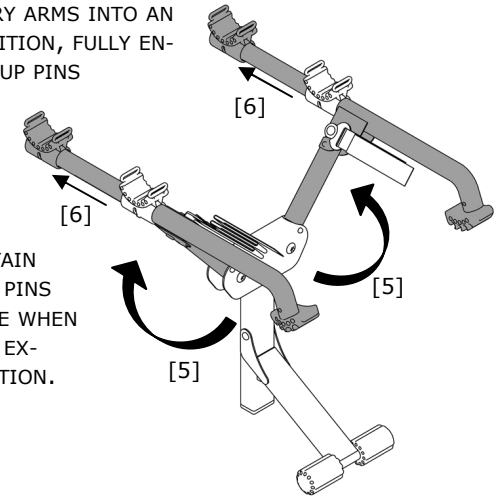

## B. BEFORE INSTALLING RACK:

1. MAKE SURE THAT CONTACT SURFACES BETWEEN CAR AND RUBBER FEET ARE THOROUGHLY CLEAN AND FREE OF DIRT. RACK PADS WILL PICK UP DIRT AND SAND IF PLACED ON THE GROUND BEFORE INSTALLATION.
2. MAKE SURE THAT ALL BUCKLES ARE THREADED AS SHOWN ON RIGHT.
3. TIE A HALF-HITCH KNOT BELOW BUCKLE FOR SAFETY ONCE TOP STRAP LENGTH IS SET
4. INSPECT ALL STRAPS TO MAKE SURE THAT THEY ARE NOT WORN OR DAMAGED IN ANY WAY.

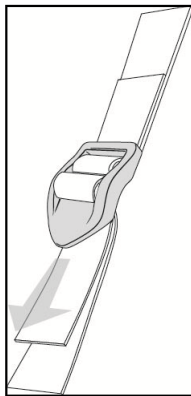

## C. INSTALLING RACK ON VEHICLE:

1. TOP HOOKS MUST BE COMPLETELY HOOKED OVER METAL EDGES AT TOP OF TRUNK, REAR DOOR, OR HATCHBACK. NEVER HOOK TO RAIN GUTTERS, ROOF RACKS, VERTICAL GLASS OR PLASTIC MOLDINGS. OPEN TRUNK/ HATCH SLIGHTLY FOR EASIEST ATTACHMENT OF HOOKS. **MAKE SURE THAT HOOKS DO NOT BIND WHEN TRUNK/ HATCH IS OPENED. BINDING HOOKS WILL DAMAGE VEHICLE.**
2. SET LENGTH OF TOP STRAPS TO POSITION RACK WITH ITS CARRY ARMS INCLINED SLIGHTLY UPWARDS, AND HIGH ENOUGH TO KEEP BIKES AWAY FROM ROAD AND EXHAUST.
3. ONCE THE LENGTH OF THE TOP STRAPS ARE SET, THE BOTTOM FOOT ASSEMBLY SHOULD BE HELD AGAINST THE VEHICLE IN ITS COMPLETELY OPEN POSITION. IT IS IMPORTANT THAT THE BOTTOM RUBBER PADS ARE INSTALLED ON THE VEHICLE IN A LOCATION WHERE THERE IS PROPER SUPPORT. THE BOTTOM FEET SHOULD NEVER BE INSTALLED ON GLASS.
4. COMPLETELY HOOK BOTTOM HOOKS TO A METAL EDGE BELOW BUMPER, OR AT THE BOTTOM OF THE TRUNK/ REAR DOOR. *IF THERE IS NO METAL EDGE BELOW BUMPER, SEE ALTERNATE METHOD FOR BOTTOM HOOK ATTACHMENT ON THE NEXT PAGE.*
5. COMPLETELY TIGHTEN BOTTOM STRAPS BY PULLING ON FREE END OF STRAP UNTIL ELASTIC PORTION OF STRAP IS FULLY STRETCHED.

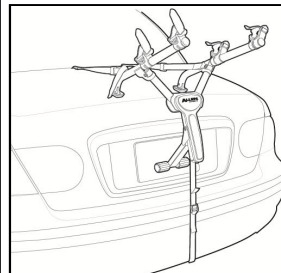

MT-2 ON SEDAN

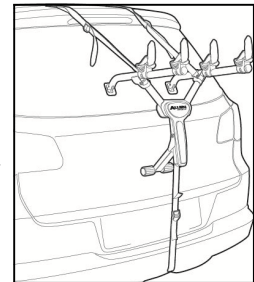

MT-2 ON SUV

**SECURING TOP HOOKS ON VEHICLES WITHOUT ADEQUATE CLEARANCE AT THE TOP EDGE OF REAR TRUNK/ HATCH:** CAREFULLY PLACE TOP HOOKS INSIDE OF VEHICLE (JUST INSIDE OF TOP EDGE OF REAR TRUNK/ HATCH). **CAREFULLY** CLOSE REAR TRUNK/ HATCH ON TOP STRAPS EXTENDING FROM TOP HOOKS, MAKING CERTAIN THAT HOOKS OR BUCKLES DO NOT BIND BETWEEN FRAME AND REAR DOOR. **IMPORTANT:** WITH REAR DOOR CLOSED, PULL TOP STRAPS TO BRING HOOKS TIGHT AGAINST INSIDE OF VEHICLE. RE-THREAD TOP STRAPS AS SHOWN IN **SECTION B** AND MOUNT RACK ON VEHICLE.

### D. ALTERNATE METHOD #1 FOR BOTTOM STRAP:

USE IF THERE IS NO METAL EDGE BELOW BUMPER FOR ATTACHMENT OF HOOKS

- REMOVE BOTTOM STRAP FROM BOTTOM STRAP BRACKET, AND THREAD BOTTOM STRAP THROUGH SLOT IN SPINE COVER. ATTACH HOOK TO LOWER EDGE OF TRUNK/ REAR HATCH. TIGHTEN BOTTOM STRAP.

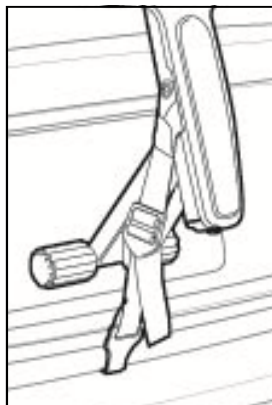
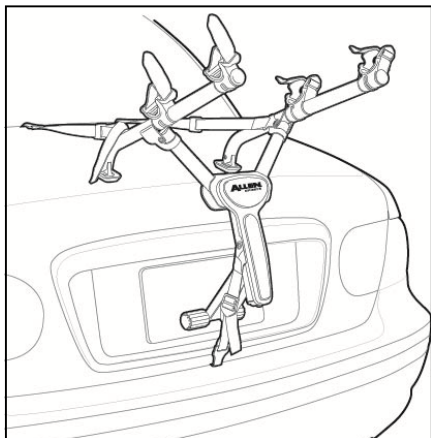

DETAILED VIEW

### E. ALTERNATE METHOD #2 FOR BOTTOM STRAP:

USE IF THERE IS NO METAL EDGE BELOW BUMPER OR ON TRUNK FOR ATTACHMENT OF HOOKS

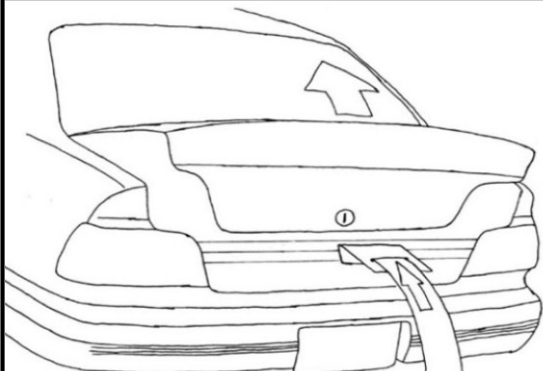

- BEFORE INSTALLING RACK ON VEHICLE, REMOVE BOTTOM STRAPS OPEN TRUNK SLIGHTLY AND PLACE BOTTOM HOOKS JUST INSIDE OF TRUNK/ HATCH. CAREFULLY CLOSE TRUNK ON BOTTOM STRAP. PULL STRAPS TO BRING HOOKS AGAINST THE INSIDE

OF TRUNK. MOUNT RACK ONTO CAR AS DESCRIBED IN SECTION C. RETHREAD BOTTOM STRAPS AND TIGHTEN.

### F. LOADING BICYCLES ON RACK:

1. REMOVE ALL LOOSE ITEMS FROM BICYCLES (PUMPS, BAGS, ETC.), AND CHECK THAT ALL QUICK RELEASE HUBS ARE TIGHT. CARRY ARMS MUST BE SECURED IN EXTENDED POSITION TO CARRY TWO BICYCLES.
2. LOAD FIRST BICYCLE WITH ITS CHAIN AND GEARS FACING AWAY FROM RACK. ADJUST BICYCLE SO THAT FRAME RESTS AGAINST THE PADDED VERTICAL SPINE ON RACK, MAKING SURE THAT NO PART OF THE BICYCLE COMES IN CONTACT WITH VEHICLE.
3. LOAD SECOND BICYCLE IN OPPOSITE DIRECTION FROM FIRST. FOR BEST WEIGHT DISTRIBUTION, LOAD HEAVIEST BICYCLE FIRST. ADD PADDING BETWEEN BICYCLE CONTACT POINTS IF NECESSARY.
4. AFTER BICYCLES ARE LOADED, CHECK THAT ENTIRE RACK IS SECURE, AND THAT THE RACK IS FIRMLY IN PLACE. VISION OUT OF REAR WINDOW MAY BE RESTRICTED—USE SIDE MIRRORS ACCORDINGLY WHEN BACKING UP.

#### SPECIAL NOTE ON INSTALLING WOMEN'S STYLE FRAMES:

PLACE ONE CARRY ARM UNDER FRONT TOP TUBE. WITH THE OTHER CARRY ARM, ROTATE TIE-DOWN CRADLE, AND PLACE CARRY IN SPACE BEHIND SEAT TUBE AND BELOW REAR DOWN-STAY. THE ALLEN 900B ADAPTOR BAR IS ALSO RECOMMENDED FOR THIS APPLICATION.

### G. SECURING BIKES TO RACK:

BICYCLE MUST BE SECURELY TIED TO RACK. USE INDIVIDUAL TIE-DOWN STRAPS, OR ADDITIONAL STRAPS IF NECESSARY.

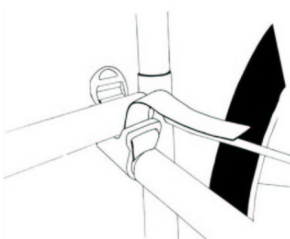

1. PLACE BICYCLE IN CRADLE.

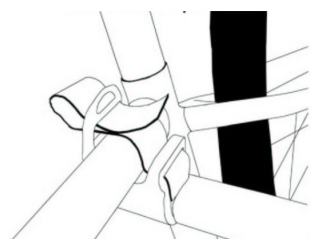

2. THREAD STRAPS.

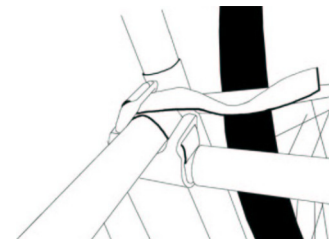

3. PULL STRAP TIGHT.

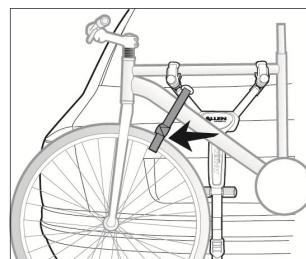

#### IMPORTANT:

SECURE FRONT WHEEL OF BICYCLE WITH EXCESS BOTTOM STRAP, OR ADDITIONAL STRAPS TO PREVENT WHEEL FROM COMING INTO CONTACT WITH VEHICLE.

#### ALLEN LIFETIME WARRANTY:

IF AN ALLEN BIKE RACK IS FOUND TO HAVE A DEFECT IN WORKMANSHIP OR MATERIAL OVER THE LIFETIME OF THE ORIGINAL PURCHASER, ALLEN WILL REPAIR OR REPLACE THE RACK FREE OF CHARGE.

TO VIEW AN INSTRUCTIONAL VIDEO ON THIS ITEM, SCAN THE QR CODE (BELOW), OR VISIT: [WWW.ALLENSPORTSUSA.COM/INSTRUCTIONAL-VIDEOS](http://WWW.ALLENSPORTSUSA.COM/INSTRUCTIONAL-VIDEOS)

R. A. ALLEN CO., INC.—ALLEN BIKE RACKS  
505 BEACHLAND BLVD.—SUITE 5  
VERO BEACH, FL 32963  
(800) 722-5536 - FAX: (772) 234-5796

WWW.ALLENRACKS.COM - CUSTOMERSERVICE@ALLENRACKS.COM  
©2012 R. A. ALLEN CO., INC., ALL RIGHTS RESERVED  
DESIGNED IN USA - MADE IN CHINA - PATENT PENDING

