

WARNING: BIKES OR RACK FALLING IN ROAD CAN CAUSE SERIOUS ACCIDENTS RESULTING IN BODILY INJURY—DO NOT USE RACK ON ANY VEHICLE ON WHICH IT CAN NOT BE PROPERLY MOUNTED AS DESCRIBED IN THIS INSTRUCTION SHEET.

- Use this rack only on rear mounted external spare tires. Make sure that spare tire is securely attached and that the tire is fully inflated.
- Never use rack on spare tires mounted on any type of trailer, RV, or on the front of vehicle.
- Never carry more than 3 bicycles (MAX CAPACITY: 100 LB) - no tandems, mopeds, or recumbents. Car tail lights must remain visible. Bikes must be securely tied to rack. Use bike tie-downs, or additional straps if necessary.
- Drive conservatively, especially over bumps. Never use off-road.
- Do not use if any part of the rack is damaged, worn, or missing. Contact R. A. Allen Co., Inc. for replacement parts.

CAUTION: Use Allen 303S only in accordance with local motor vehicle and traffic regulations.

- To avoid damage to rear door, do not open rear door when hooks or rack are in place.
- Install rack and load bicycles only at a safe distance away from moving traffic.
- Only hooks on rack should come into contact with car.
- Make sure that all of rack and bicycles are kept at a safe distance from road and hot exhaust.
- Remove rack from car when not in use

A. SETTING UP RACK:

1. FOLD OUT TOP FOOT/ CARRY-ARM ASSEMBLY [A].

2. SET-UP PINS WILL "SNAP" INTO PLACE.

3. COMPLETELY FOLD OUT BOTTOM FOOT ASSEMBLY [B].

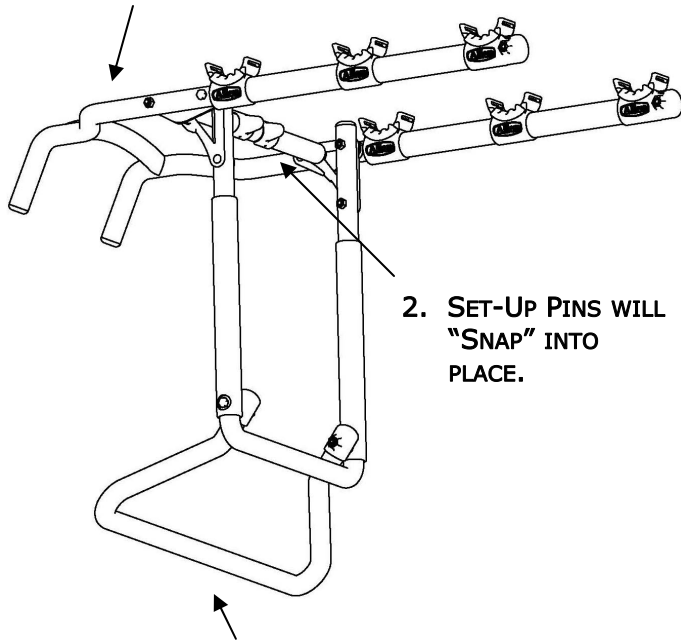

B. INSTALLING RACK ON TIRE:

1. ONLY USE RACK ON REAR MOUNTED EXTERNAL SPARE TIRES INSTALLED ON STANDARD AUTOMOBILES AND TRUCKS. **NEVER** USE RACK ON TRAILERS OR RV'S. MAKE SURE THAT SPARE TIRE IS SECURELY ATTACHED AND FULLY INFLATED.

2. BEFORE INSTALLING, REMOVE ANY SPARE TIRE COVERS THAT MAY BE DAMAGED BY RACK.

3. COMPLETELY HOOK TOP FOOT/ CARRY ARM ASSEMBLY [A] OVER THE TOP OF SPARE TIRE. POSITION RACK WITH CARRY ARMS INCLINED SLIGHTLY UPWARDS AND HIGH ENOUGH TO KEEP TAIL LIGHTS VISIBLE.

4. BOTTOM FOOT ASSEMBLY [B] MUST BE HELD AGAINST THE TIRE IN A FULLY EXTENDED POSITION.

5. COMPLETELY HOOK BOTTOM HOOKS TO A METAL EDGE BELOW BUMPER, OR AT THE BOTTOM OF THE REAR DOOR.

6. OPENING REAR DOOR SLIGHTLY CAN MAKE IT EASIER TO ATTACH BOTTOM HOOKS

5. IF THERE IS NO METAL EDGE AT THE BOTTOM OF REAR DOOR, LOOK FOR A METAL EDGE BELOW THE BUMPER. ALTERNATIVELY, THE STRAPS CAN BE LOOPED AROUND BAR STYLE BUMPERS.

6. COMPLETELY TIGHTEN BOTTOM STRAPS BY PULLING ON FREE END OF STRAPS UNTIL ELASTIC PORTION OF STRAPS ARE COMPLETELY STRETCHED.

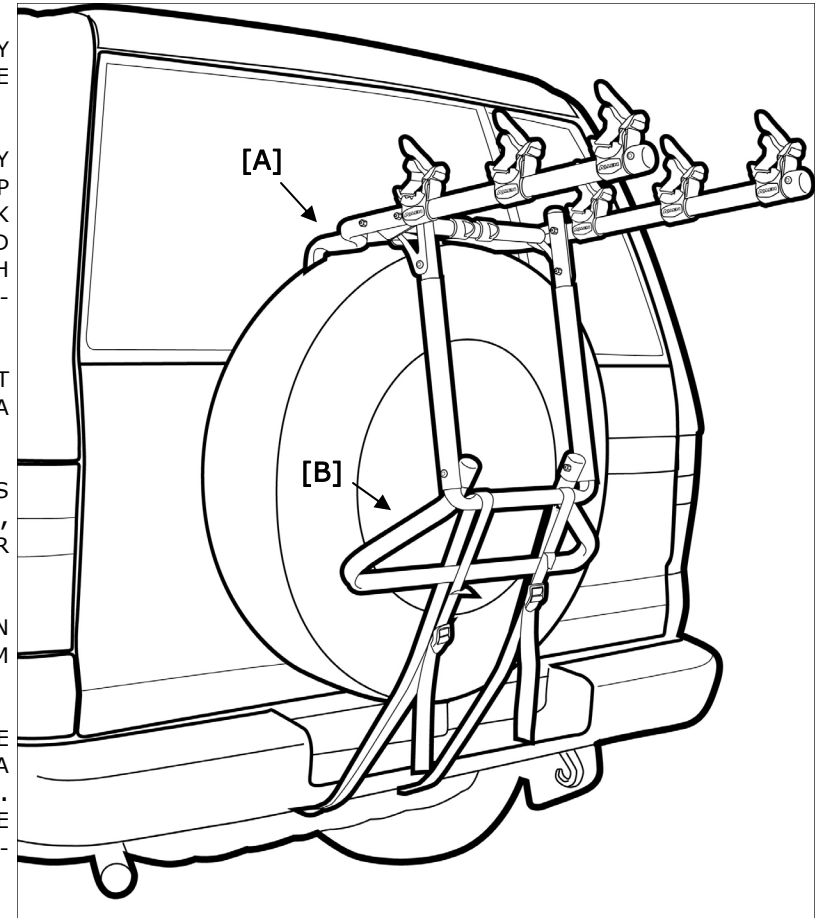

F. LOADING BICYCLES ON RACK:

1. REMOVE ALL LOOSE ITEMS FROM BICYCLES (PUMPS, BAGS, ETC.), AND CHECK THAT ALL QUICK RELEASE HUBS ARE TIGHT.
2. LOAD FIRST BICYCLE WITH ITS CHAIN AND GEARS FACING AWAY FROM RACK. MAKE SURE THAT BICYCLES DO NOT COME IN CONTACT WITH VEHICLE.
3. LOAD SUBSEQUENT BICYCLES IN ALTERNATING DIRECTIONS. FOR BEST WEIGHT DISTRIBUTION, LOAD HEAVIEST BICYCLES FIRST, WITH LIGHTER BICYCLES ON THE OUTSIDE. ADD PADDING BETWEEN BICYCLE CONTACT POINTS, IF NECESSARY.
4. AFTER BICYCLES ARE LOADED, CHECK THAT ENTIRE RACK IS SECURE, AND THAT THE RACK IS STILL FIRMLY IN PLACE. VISION OUT OF REAR WINDOW MAY BE RESTRICTED—USE SIDE MIRRORS ACCORDINGLY WHEN BACKING UP.

SPECIAL NOTE ON INSTALLING WOMEN'S STYLE FRAMES:

PLACE ONE CARRY ARM UNDER FRONT TOP TUBE. WITH THE OTHER CARRY ARM, ROTATE TIE-DOWN CRADLE, AND PLACE CARRY IN SPACE BEHIND SEAT TUBE AND BELOW REAR DOWN-STAY. THE **ALLEN 900B ADAPTOR BAR** IS ALSO RECOMMENDED FOR THIS APPLICATION.

G. SECURING BIKES TO RACK:

ALL BIKES MUST BE SECURELY TIED TO RACK. USE INDIVIDUAL TIE-DOWN STRAPS, OR ADDITIONAL STRAPS IF NECESSARY.

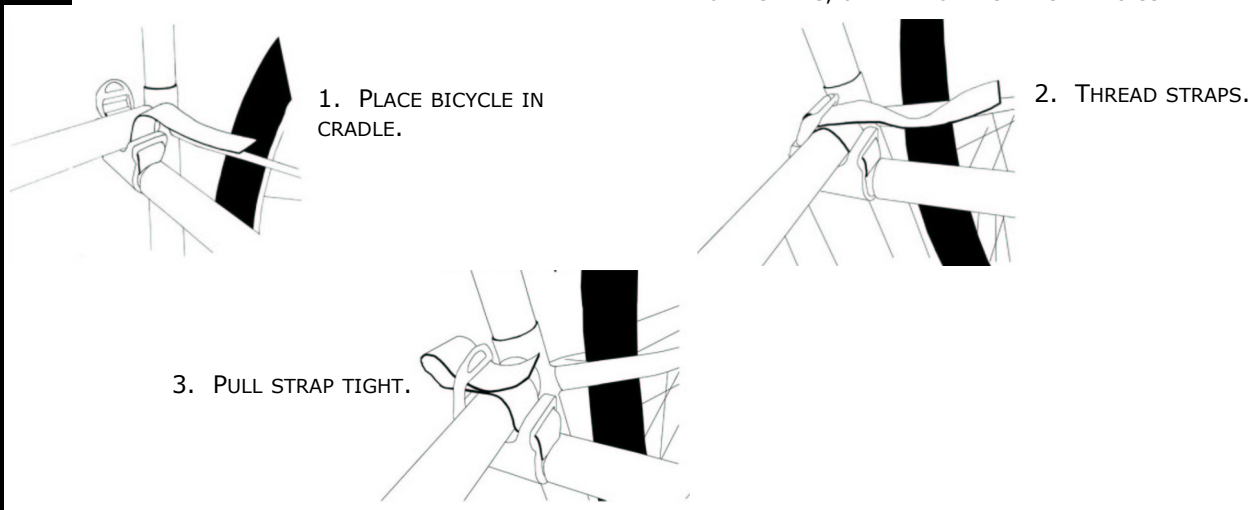
**ALLEN LIFETIME WARRANTY:**

IF AN ALLEN BIKE RACK IS FOUND TO HAVE A DEFECT IN WORKMANSHIP OR MATERIAL OVER THE LIFETIME OF THE ORIGINAL PURCHASER, ALLEN WILL REPAIR OR REPLACE THE RACK FREE OF CHARGE.

R. A. ALLEN CO., INC.
505 BEACHLAND BLVD.—SUITE 5
VERO BEACH, FL 32963
(800) 722-5536
FAX: (772) 234-5796

WWW.ALLENRACKS.COM - CUSTOMERSERVICE@ALLENRACKS.COM